

BASIC HALOGEN-, LEDTAK FÖR SKÅP.

ART. NR 5858006000/10/11.

ART. NR 5858206000/10/11.

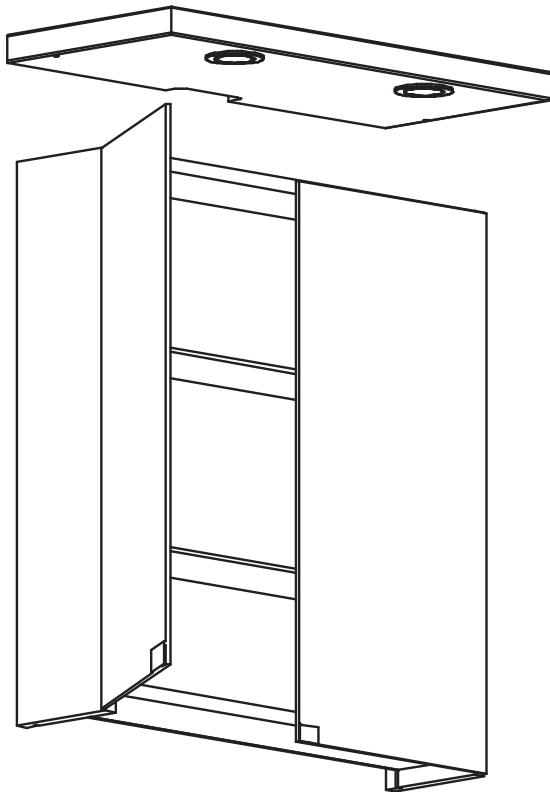

S MONTERINGSANVISNING
GB ASSEMBLY INSTRUCTION

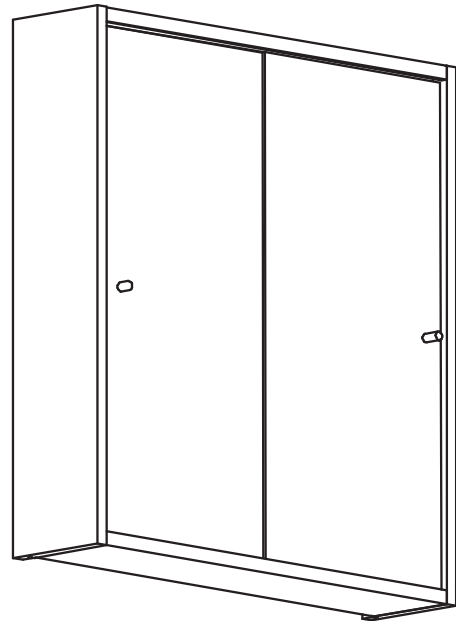

BASIC SKJUTSPEGELSKÅP 600.

ART. NR 5250306000.

BASIC SPEGELSKÅP 600.

ART. NR 5250506000/10/11.

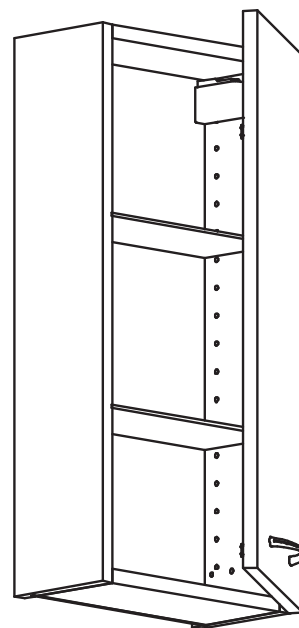
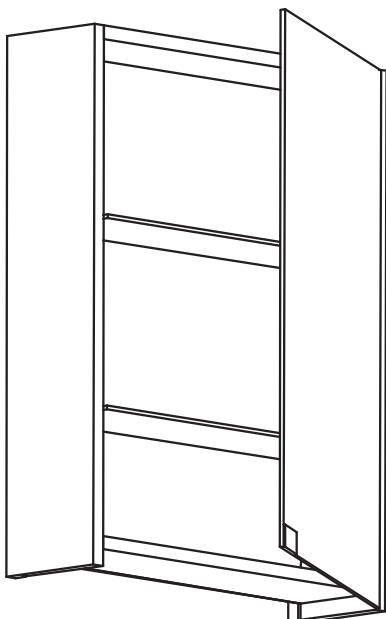

BASIC SPEGELSKÅP 500.

ART. NR 5250505000/10/11.

BASIC ÖVERSKÅP 300.

ART. NR 5200603000/10/11.

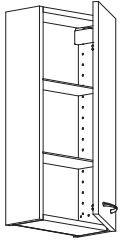
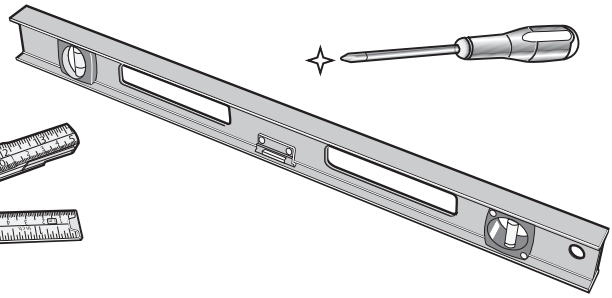
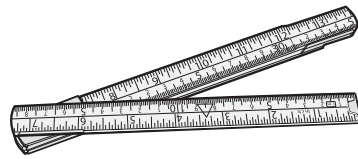
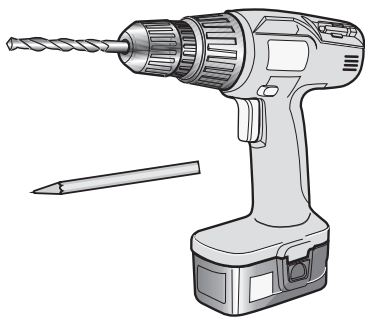

BASIC ÖVERSKÅP 300

Placering av
gångjärnsplatta vid
VÄNSTERHÄNGD
LUCKA.

*Hingeplate location
for left-hung door.*

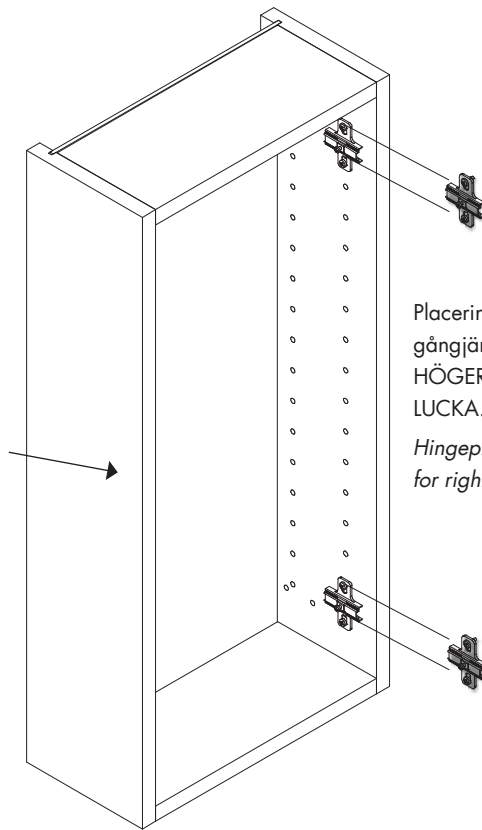

Placering av
gångjärnsplatta vid
HÖGERHÄNGD
LUCKA.

*Hingeplate location
for right-hung door.*

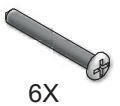
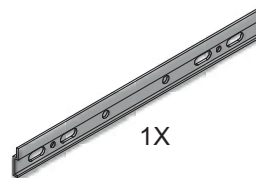
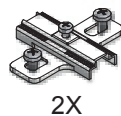
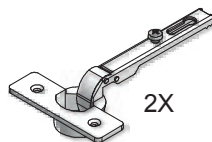
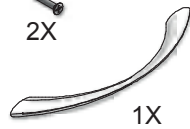
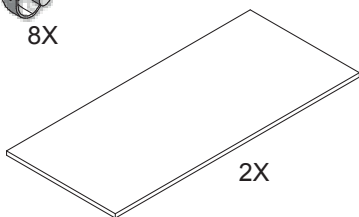
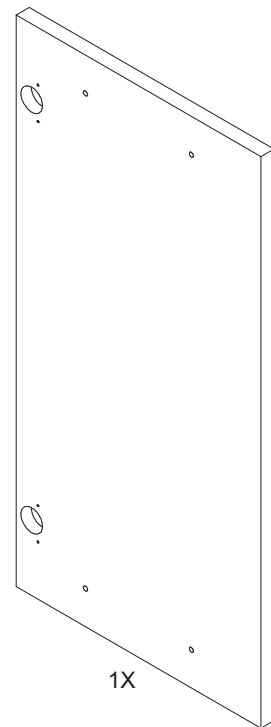

BASIC SPEGELSKÅP 500

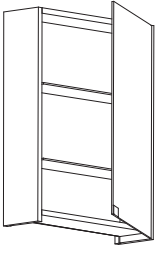

Placering av
gångjärnsplatta vid
VÄNSTERHÄNGD
LUCKA.

*Hingeplate location
for left-hung door.*

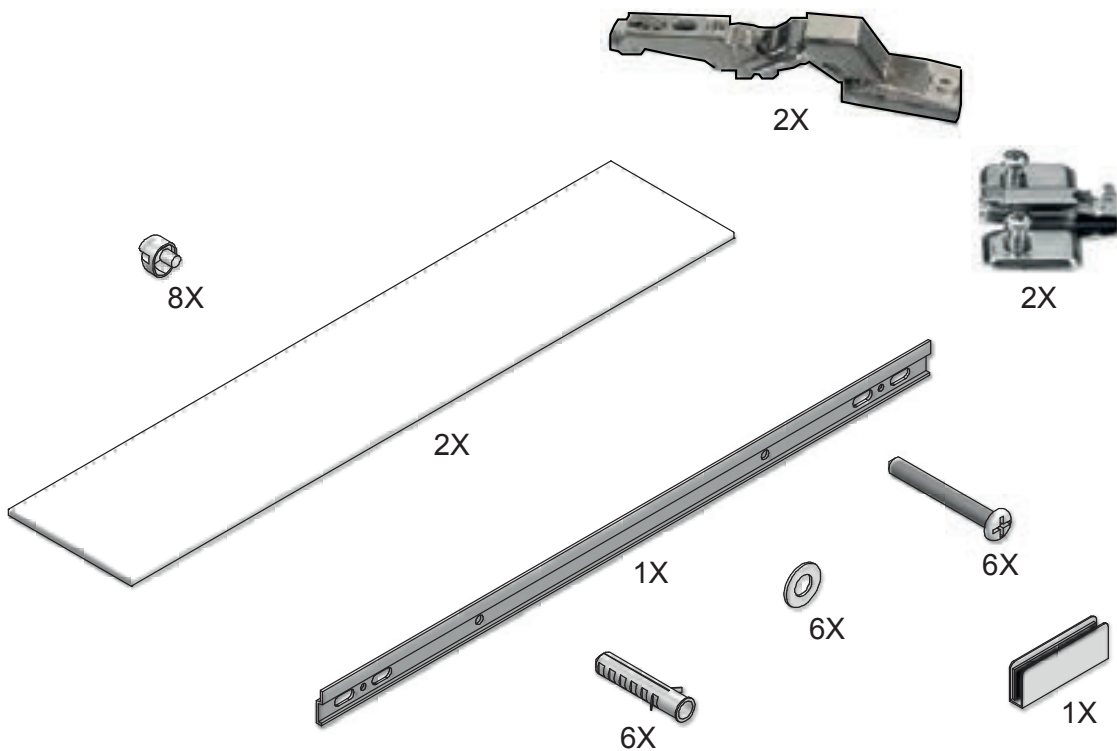
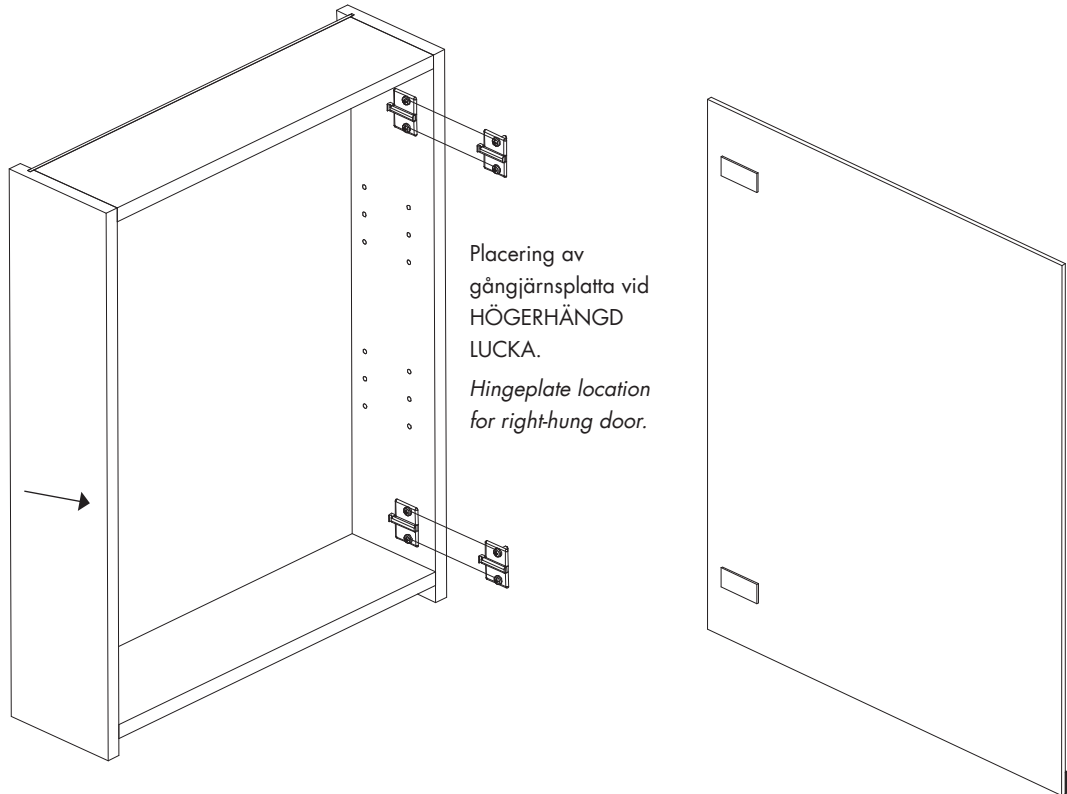

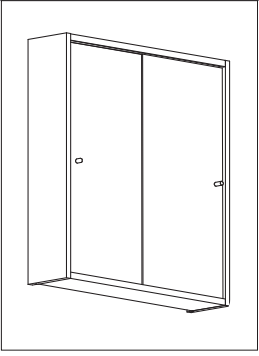

BASIC SKJUTSPEGELSKÅP 600

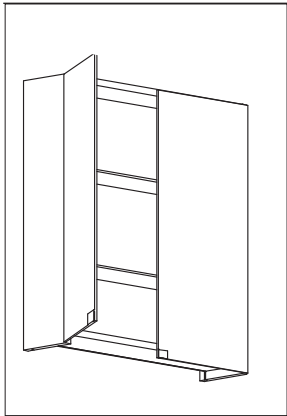
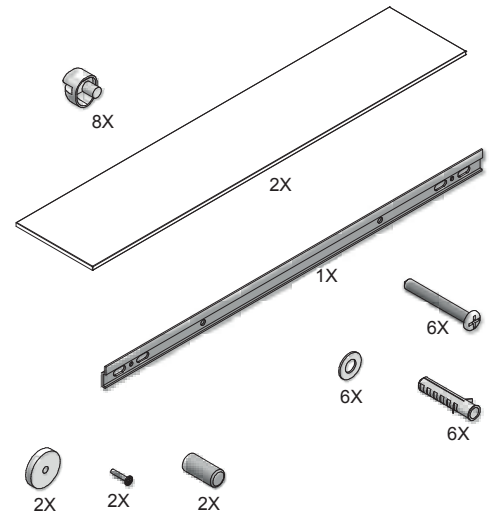
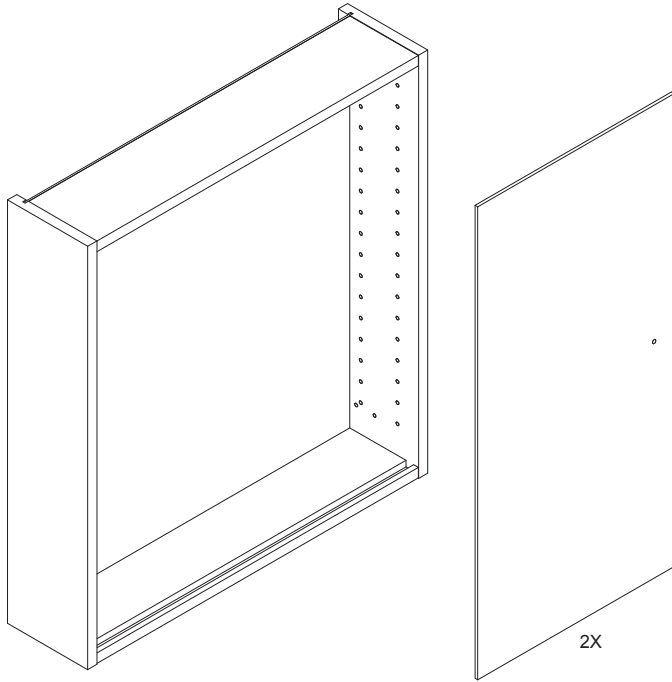

BASIC SPEGELSKÅP 600

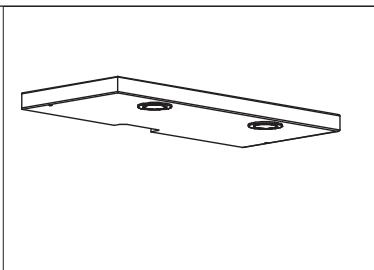
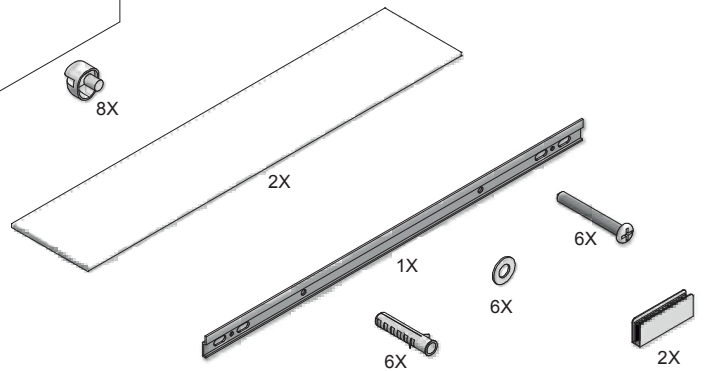
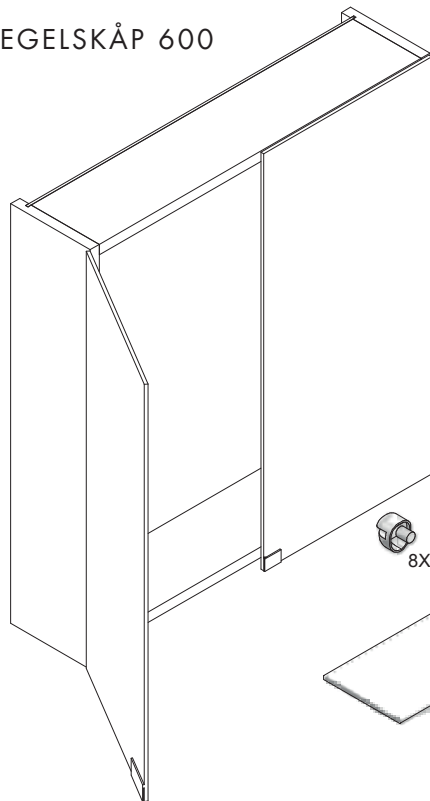

BASIC HALOGEN-, LEDTAK FÖR SKÅP



1

UPPHÄNGNING PÅ VÄGGSKENA / MOUNTING ON WALLBRACKET

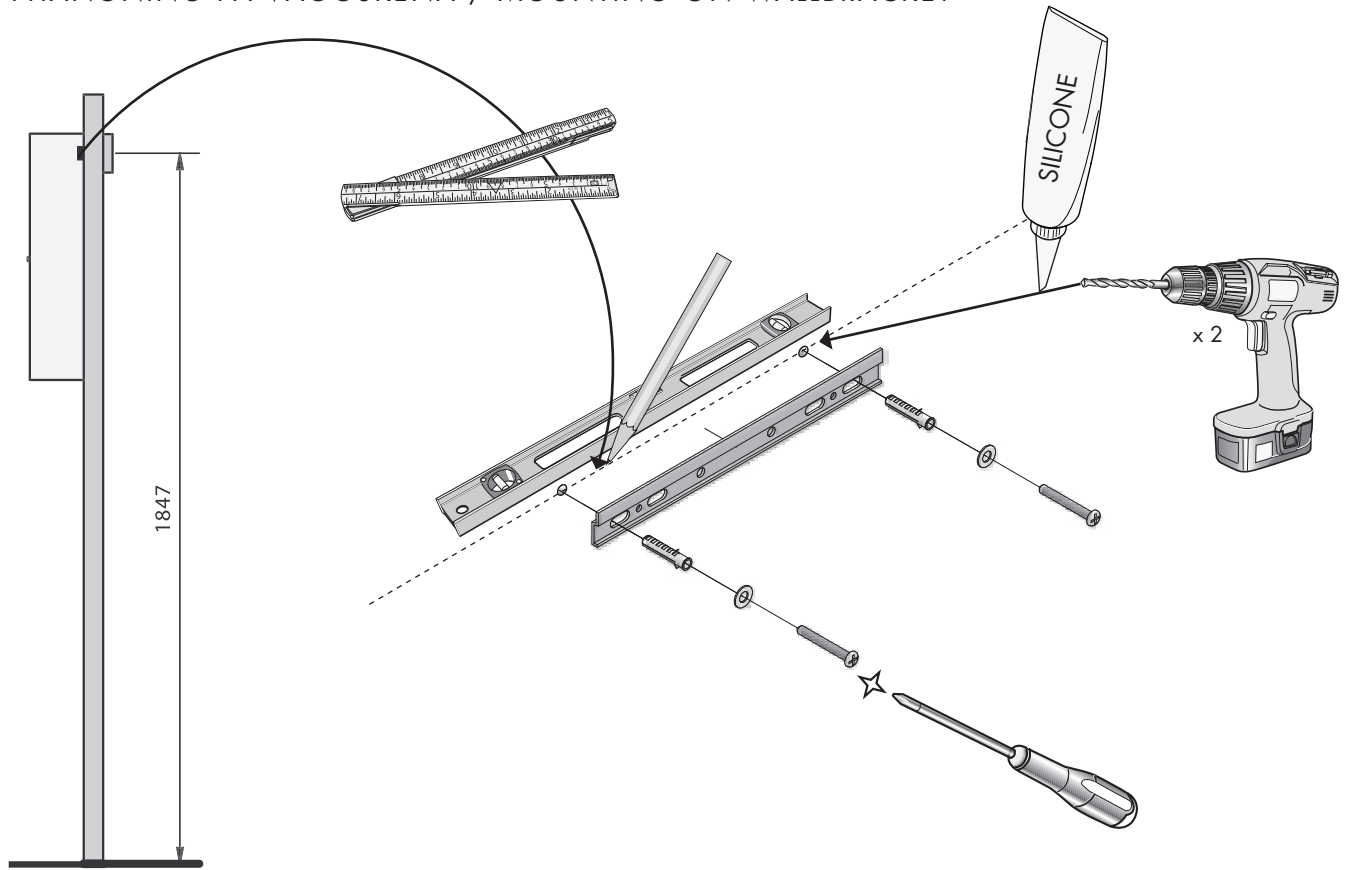

2

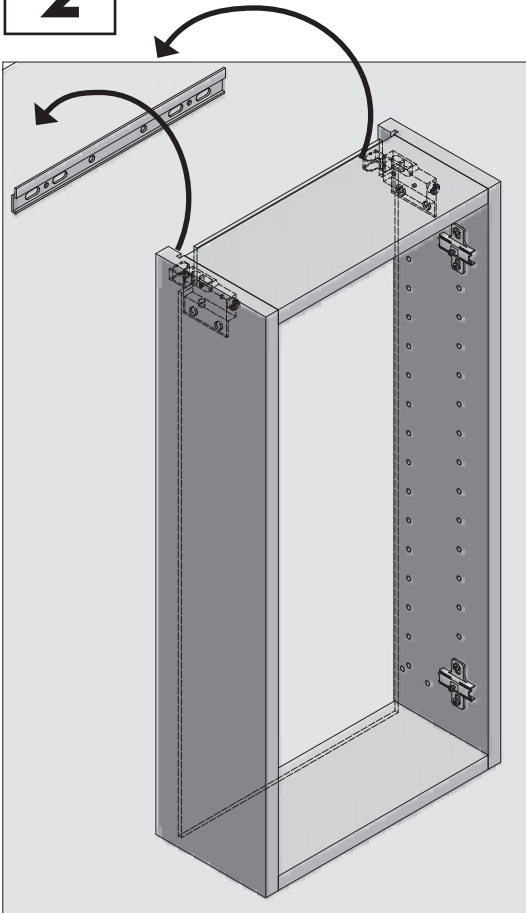

3

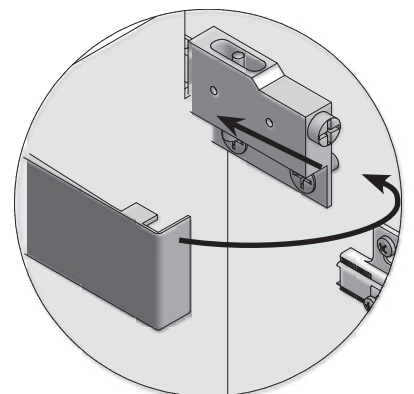
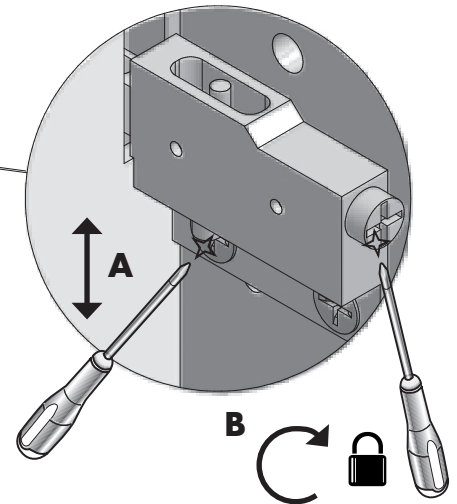
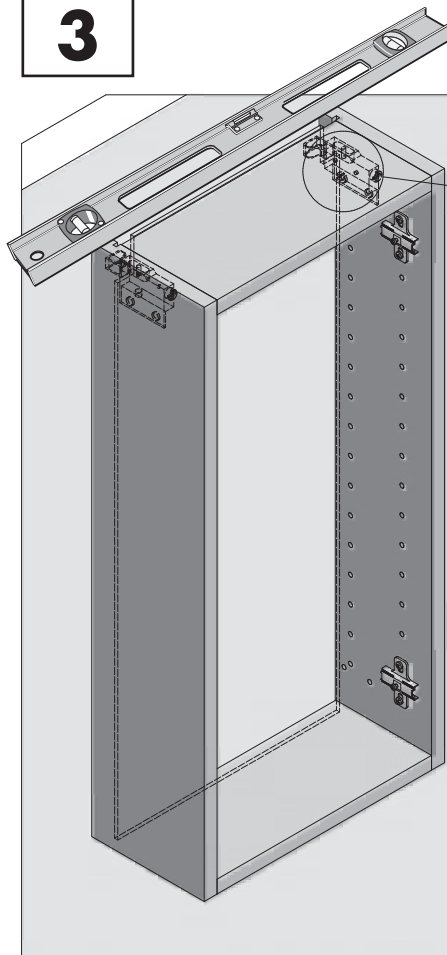

HALOGENTAK FÖR SPEGELSKÅP / HALOGENROOF FOR MIRROR CABINET

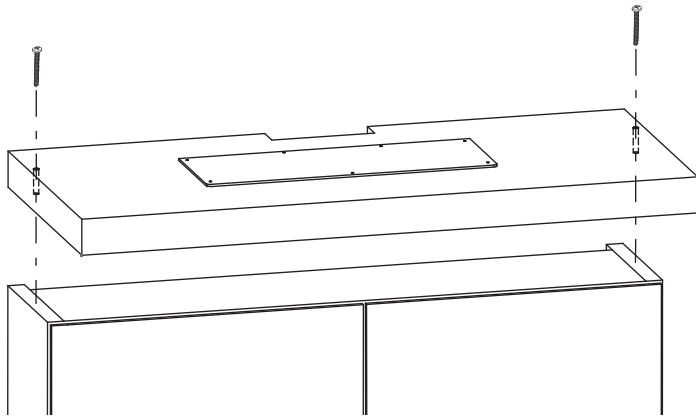

MONTERING AV HALOGENTAK

Placera belysningen centrerat i sidled och jämnt i bakkant med spegelskåpet. Skruva fast belysningen med medföljande skruv.

ASSEMBLY OF ROOF FOR MIRRORCABINET

Place the light centred sideways and in line with the back of the mirror-cabinet. Secure roof with attached screws.

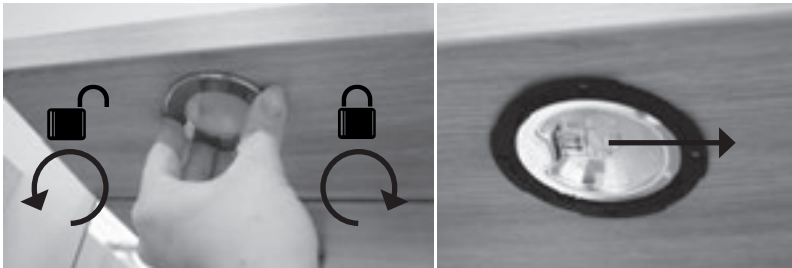

BYTE AV HALOGENLAMPAN

Lossa halogenglasets genom att vrida det motsols. Byt lampa genom att dra den rakt ut. Sätt i ny lamp. Sätt tillbaka halogenglasets genom att vrida det medsols tills det fastnar.

TO EXCHANGE THE LAMP

Remove the halogen glass by turning it counterclockwise. - Exchange the lamp. - Put the halogen glass back again by turning it clockwise until it locks.



230 V ELUTTAG

Det går att placera ett eluttag inne i spegelskåpet, detta ansluts via halogentaket. Borra hål för eluttagets sladd i spegelskåpet och dra sladden upp bakom spegelskåpets rygg. I halogentaket finns ingångshål för sladden. OBS All elanslutning ska utföras av behörig elektriker, se säkerhetsanvisning.

See for local directions concerning the electrical installation.

SÄKERHETSANVISNING EL!

Armaturen skall installeras av behörig elektriker. För halogenbelysning är minsta tillåtna avstånd till belyst föremål 150 mm.

Belysning med uttag 230 V skall anslutas över en jordfelsbrytare med högst 30 mA märkutlösingsström. Se även starkströmsföreskrifter för uttag i badrum/duschrum när det gäller placering av armaturens uttag.

SAFETY DIRECTIONS

See local directions concerning the electrical installation.

HÖJD FÖR ELUTGÅNG

Lämplig höjd för elinstallationer visas nedan. Måtten är i mm, i mitten av belysningen.

Basic halogenbelysning för spegel 1890
Basic halogentak för spegelskåp 1920

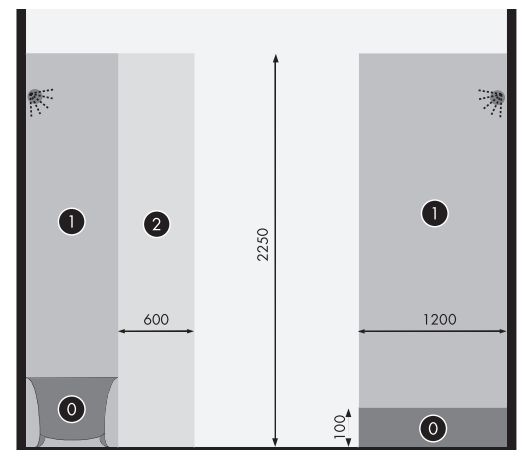

Badkar alt. dusch med kar.

Dusch utan kar.

- 0** Område 0: Kräver minst IPX7
- 1** Område 1: Kräver minst IPX4
- 2** Område 2: Kräver minst IPX4
- Oklassat område: Får 230 V uttag kopplat till jordfelsbrytare placeras.



DEMONTERING AV SPEGELLUCKA 600 DISMOUNTING OF MIRRORDOOR 600

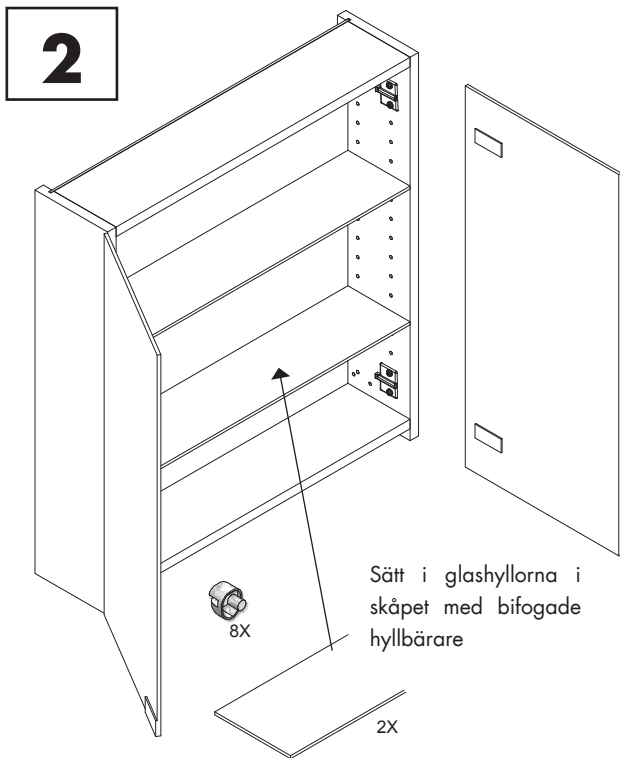
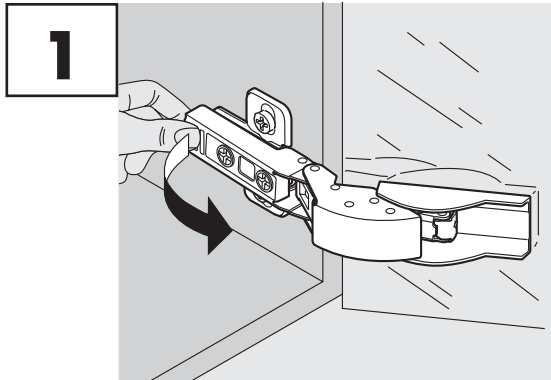

MONTERING AV SPEGELLUCKA 600 / ASSEMBLY OF MIRRORDOOR 600

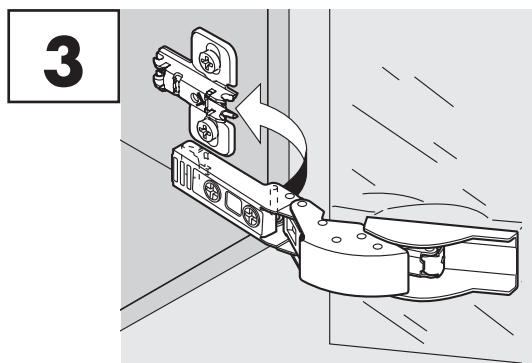

MONTERING AV SPEGELLUCKA 500 / ASSEMBLY OF MIRRORDOOR 500

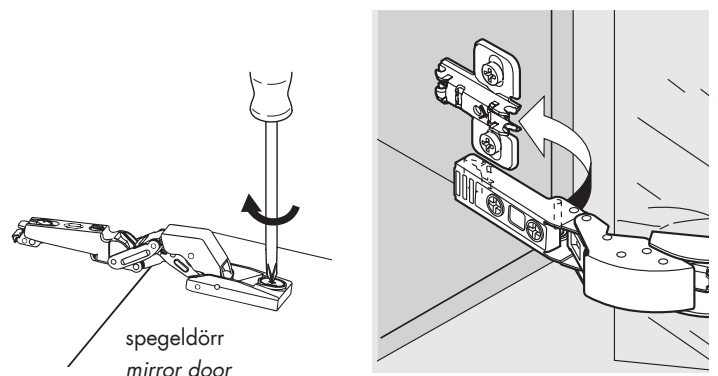
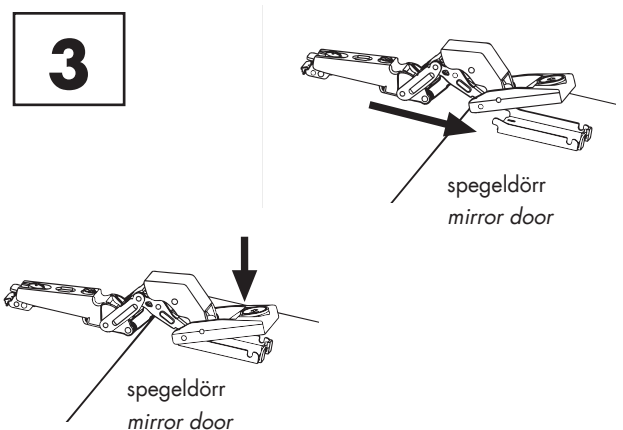
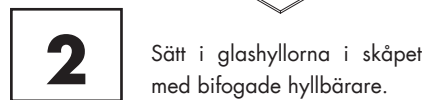
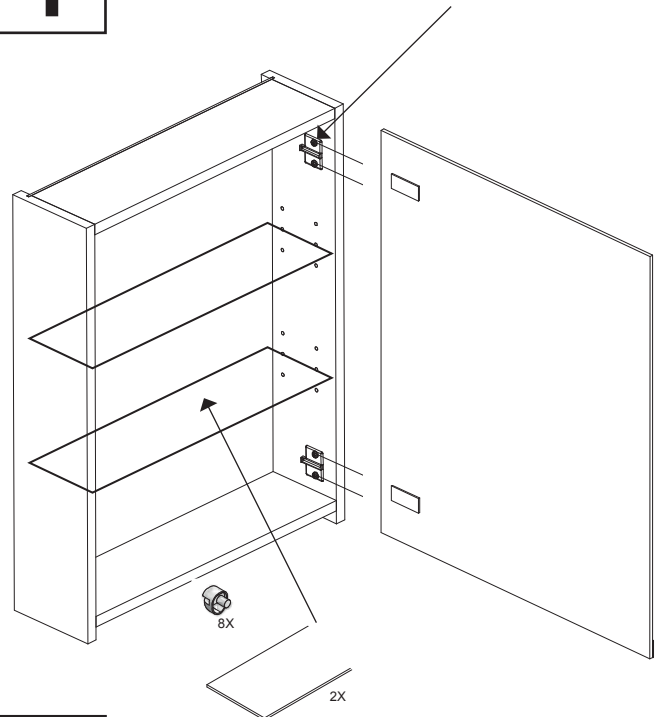
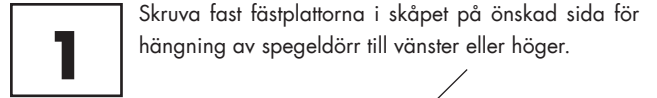

MONTERING AV LUCKA / ASSEMBLY OF DOORS

1

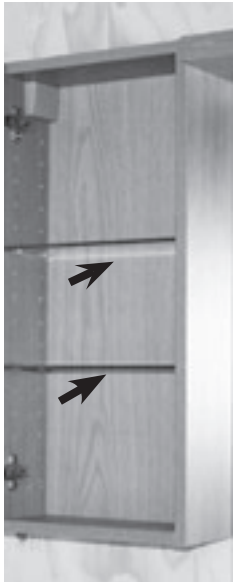

Börja med glashyllorna!
Start with the shelves!

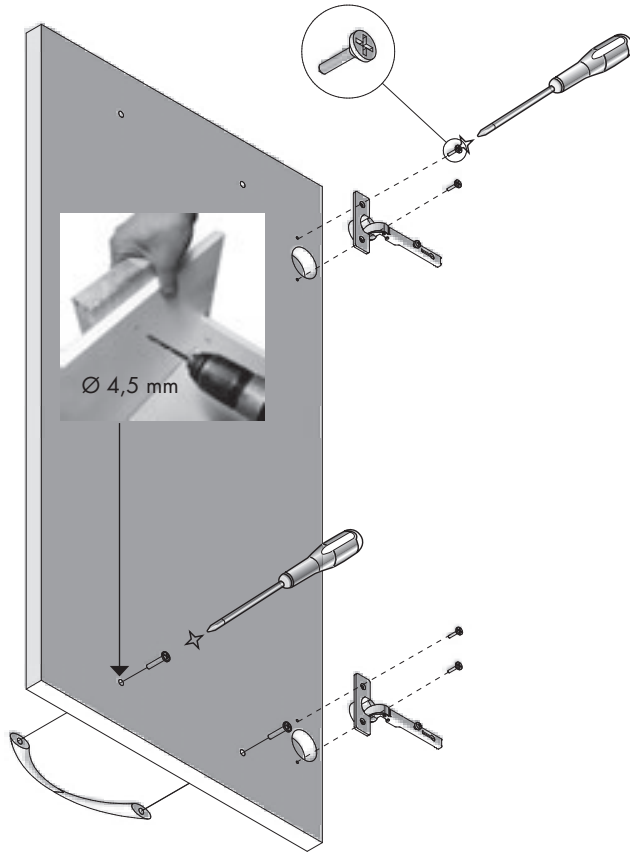

2

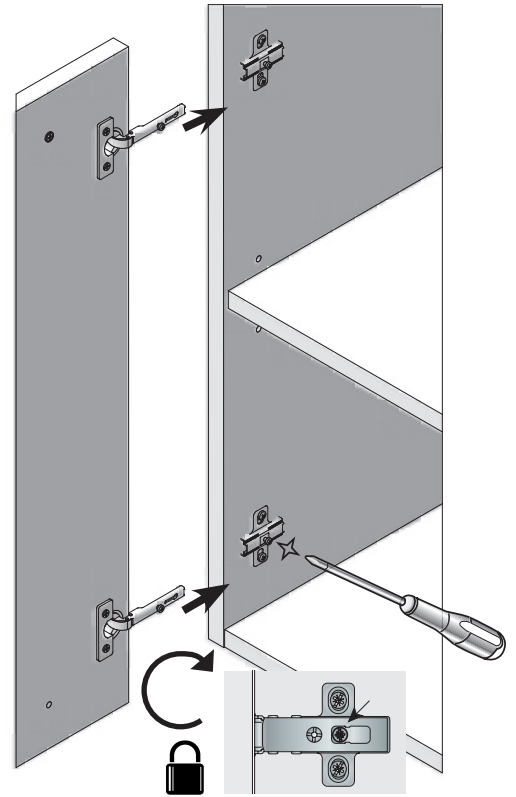

JUSTERING AV LUCKA / ADJUSTMENT OF DOORS

